



Butler

Librak

ELECTRONIC WHEEL BALANCERS WITH MICROPROCESSOR



Automatic storage of distance and diameter.



Automatic programs.



Quick selection with internal data gauge.



Rim run-out measurement with internal data gauge.



LIBRAK 355

WHEEL BALANCERS



EFFICIENCY AND MONEY SAVING

Modern balancing system to minimize wheel weights consumption.



Quick balancing process thanks to the automatic start when the cover is lowered and automatic stop of the wheel in the external unbalanced position.





LIBRAK 355S

LIBRAK 355WS

STANDARD



GAR 111 (Ø 44-112 mm)



GAR 108 (Pneumatic Locking)

	MANUAL LOCK	LASER BLADE	+ DOUBLE LED	GAUGE	WIDTH SONAR
LIBRAK 355WS	✓	✓	✓	-	✓
LIBRAK 355S	✓	✓	✓	✓	-

TECHNICAL DATA	
Rim diameter	10"-30"
Rim width	1,5"-22"
Max Wheel weight	70 kg
Read out accuracy	1 g
Cycle time	6 s.
Rotation Speed (rpm)	<100
Power supply	110-230v 50-60/1ph

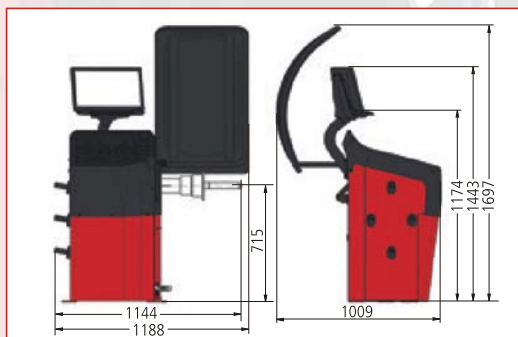

EQUIP MASTERS CORPORATION
 B 211, Arjun Centre, Plot No. 231, Govandi Station Road, Govandi East, Mumbai - 400 088.
 Tel.: +91-22-2550 3037 / 250 3038 • Email: sales@dentmasterindia.com
 Web: www.dentmastersindia.com

Technical data and composition presented in this catalogue may vary. Pictures reproduced are only indicative.